

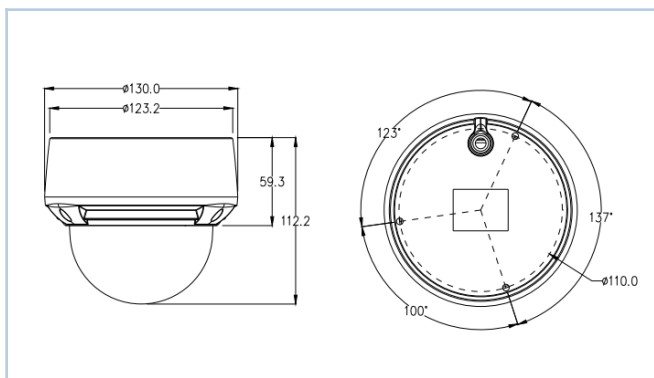

The Eagle Eye DD11 is a high-performance 8 Megapixel camera with an IP66 environmental and IK10 vandal rating. This model is suitable for indoor and outdoor use for a wide range of applications. The camera comes pre-configured to securely operate with the Eagle Eye Cloud VMS and Eagle Eye CameraManager.

Key Features

- > 8 Megapixel
- > Indoor/Outdoor Waterproof Vandal Dome
- > Durable All-Aluminum Housing, IP66 & IK10
- > Motorized Lens, 3.3-12mm
- > Wide Dynamic Range & Ultra Low Light Color
- > Night Vision Smart IR, IR LEDs, 30m range
- > Triple RTSP Streams



Camera

Pixels	8 MP
Resolutions	3840x2160/3072x2048/ 2592x1520/2560x1440/2304x1296/ 1920x1080/1280x720 @25/30fps
Lens	3.3 – 12mm motorized lens
Night Vision	Smart IR LEDs, 30m range (98ft)
Field of View	35° – 108.6°
Dynamic Range	WDR (120dB) and HLC/BLC
Digital Noise Reduction	2D/3D DNR and defog
Digital Image Stabilization	Automatic
Applications	Best for modest outdoor areas or large indoor areas: small parking lots, fields, parking garages, work yards, back yards, outdoor entrances, warehouses
Image Sensor	1/2.5" progressive scan CMOS
Iris	Fixed
Shutter Speed	1/5s to 1/20000s
Min Illumination	Color 0.01 Lux; IR on 0 Lux

Digital Capabilities

Video Compression	H.265, H.264, and MJPEG
Image Settings	Rotation, saturation, brightness, contrast, sharpness
Corridor Mode	Yes

Setup

Eagle Eye Cloud VMS	Preconfigured with secure password, plug and play
Camera Settings	Fully integrated with Eagle Eye Cloud VMS and Eagle Eye CameraManager
Cyber Secure	Eagle Eye Verified

Interface

Ethernet	Waterproof RJ-45 female 10/100Base-T
Audio	None
BNC Output	Built-in CVBS output

Physical/Power

Power	DC 12V/Power Over Ethernet (IEEE 802.3af)
Power Consumption	3.5W IR off, 8W IR on
Operating Temperature	-30°C to +50°C (-22°F to 122°F)
Operating Humidity	0% – 90% RH
Ingress Rating	IP66 and IK10
Approvals	CE/FCC
Dimensions	Φ 130 x 112mm (5.12 x 4.41in)
Weight	690g (24.34oz)
Housing	All Aluminum

Eagle Eye Part Numbers

EN-CDUD-011a	Eagle Eye Camera DD11 Indoor/Outdoor 8MP Vandal Dome IP Camera, 3.3-12mm Moto Lens, POE, IR
EN-RRC01	Eagle Eye Camera Rapid Replacement
EN-CABX-005	Eagle Eye Camera Junction Box BX005 (DM08, DD07 to DD11 ,DE02)
EN-CAWA-001	Eagle Eye Camera Wall Arm WA005 (DD08, DD09, DD11)
EN-CAPM-001	Eagle Eye Camera Pole Mount PM001 (BX002, BX003, BX004)